

SWISS GUIDED MISSILE...

On the right are trajectories of pursuit for missiles fired in succession from the same launcher at the same target. The large diagram below gives an outline of the actual control system employed by the Oerlikon Type 54 guided missile.

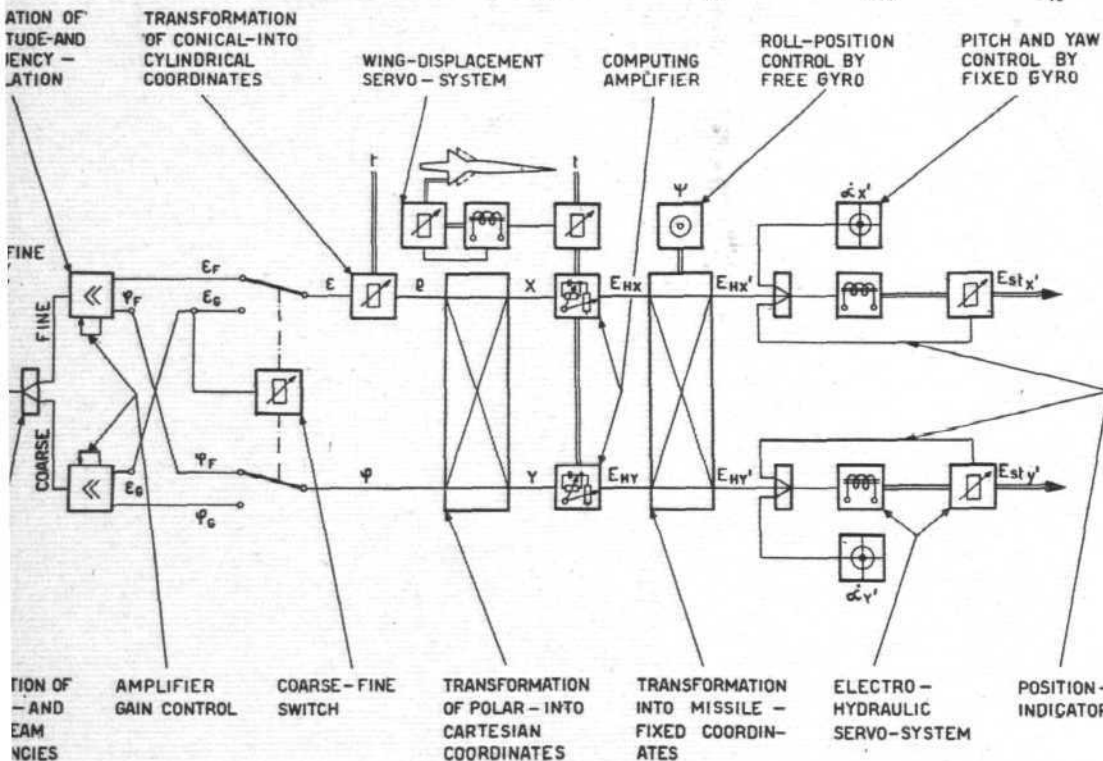
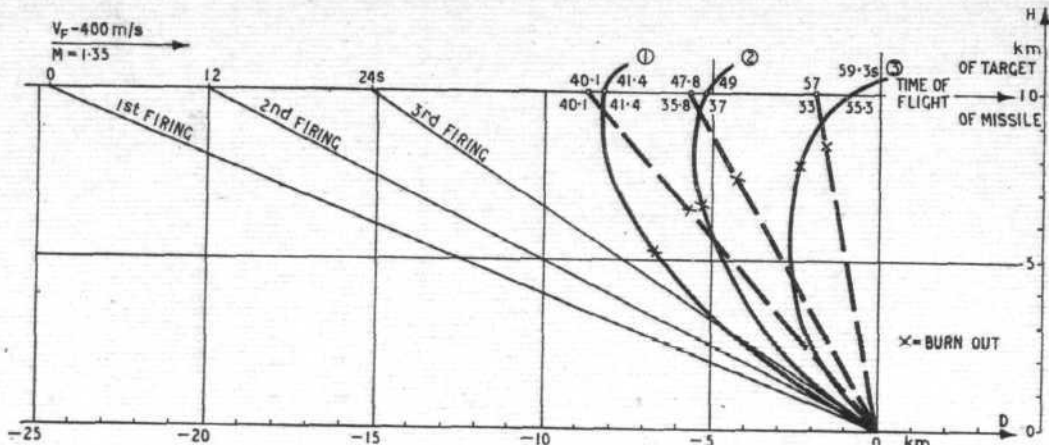

of a beam-riding missile simply by moving the beam too quickly for the missile to follow it. (The beam can be thought of as being very similar to the light from a searchlight.) The Oerlikon beam transmitter is fitted with a special computing circuit which limits the maximum angular velocity and acceleration which can be applied to the transmitting aerials.

Two illustrations show the twin launching unit which serves to hold the missile in the required position for take-off. As can be seen from the specification, the launching acceleration is almost 3g, and this is apparently sufficient to enable the weapon to be fired into the guiding beam without the need for a lengthy ramp and (more surprisingly) without any jettisonable booster section. The missile is positioned in the launching cradle by hydraulic and pneumatic circuits, the operation of which is largely automatic. The loaded launcher is then elevated to the required firing angle by electrically controlled servo mechanisms.

For the movement of the two beams, the  $\beta$ - $\zeta$  co-ordinate system has been chosen in order to avoid a singularity in the zenith. The beam transmitter is also movable about ( $\alpha$ ), provided this is done before the missile is launched.

The control system of the missile, hereafter described, can provide for continuous accelerations very much greater than those possible with manned aircraft. Nevertheless, were appropriate provision not made, it would be quite possible to lose control

able array of airborne components housed within the missile itself. These are best tabulated as follows:—

- (a) Aerials (either suppressed or flush with the missile skin) to pick up the microwave signals from the beam transmitter.
- (b) A frequency separator to distinguish between the signals from the coarse and fine beams.
- (c) Receivers for filtering and de-modulating the guidance signals.
- (d) A coarse- and fine-beam receiver for amplification, regulation and de-modulation of the sub-carrier.

The Type 54 missile is here shown about to be winched up along a ramp which places it in the right position for the catches to be engaged when the launcher is elevated.

This photograph shows the "business end" of the computer vehicle. The various items of equipment contained by this unit are described in the text.

