

EXHIBIT A

(12) **United States Patent**
Crowley et al.

(10) **Patent No.:** **US 7,400,858 B2**
 (45) **Date of Patent:** ***Jul. 15, 2008**

(54) **RADIATIVE FOCAL AREA ANTENNA TRANSMISSION COUPLING ARRANGEMENT**

(58) **Field of Classification Search** 455/575.5, 455/575.1, 90.3, 575.6, 575.7, 575.9, 115.1, 455/95, 117, 9, 405, 406, 14, 456.1, 128, 455/129, 347, 351; 340/870.03, 870.02
 See application file for complete search history.

(75) Inventors: **Robert J Crowley**, Sudbury, MA (US);
Donald N. Halgren, Manchester, MA (US)

(56) **References Cited**
 U.S. PATENT DOCUMENTS
 2,790,899 A 4/1957 Townsend
 3,099,807 A 7/1963 Oh

(73) Assignee: **AMBIT Corp.**, Manchester, MA (US)

(*) Notice: Subject to any disclaimer, the term of this patent is extended or adjusted under 35 U.S.C. 154(b) by 597 days.

This patent is subject to a terminal disclaimer.

(Continued)
 FOREIGN PATENT DOCUMENTS
 EP 0 320 913 A3 6/1989

(21) Appl. No.: **11/020,450**

(22) Filed: **Dec. 22, 2004**

(65) **Prior Publication Data**

US 2005/0192067 A1 Sep. 1, 2005

Related U.S. Application Data

(60) Division of application No. 09/634,140, filed on Aug. 8, 2000, now Pat. No. 6,885,845, which is a continuation of application No. 08/604,105, filed on Feb. 20, 1996, now Pat. No. 6,594,471, which is a continuation-in-part of application No. 08/581,065, filed on Dec. 29, 1995, now Pat. No. 5,711,014, and a continuation-in-part of application No. 08/042,879, filed on Apr. 5, 1993, now Pat. No. 5,493,702.

(51) **Int. Cl.**
H04B 3/36 (2006.01)

(52) **U.S. Cl.** **455/14**; 455/90.3; 455/456.1; 455/15

(Continued)

OTHER PUBLICATIONS

Casewell, I., "The Provision of GSM Cellular Radio Environments Within Passenger Aircraft Operating Over Europe," Racal Research Limited, *IEEE Fifth International Conference on Mobile Radio and Personal Communications*, pp. 172-176 (1989) [Abstract].

(Continued)

Primary Examiner—Tan Trinh
 (74) *Attorney, Agent, or Firm*—Don Halgren

(57) **ABSTRACT**

The present invention comprises a docking system for connecting a portable communication device to a further signal transmission line. The docking system may be arranged within a workstation such as a desk or a tray. The system may also envelope a room in a building or be located in a vehicle, to control and restrict the radiative emission from the communication device and to direct such radiation to a further remote antenna and or signal distribution system connected to the transmission line.

17 Claims, 4 Drawing Sheets

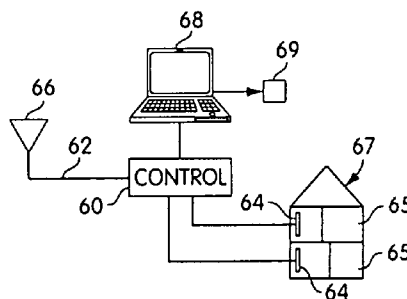

US 7,400,858 B2

Page 2

U.S. PATENT DOCUMENTS

3,364,487 A	1/1968	Maheux	5,577,264 A	11/1996	Tuohino	
3,518,681 A	6/1970	Kiepe	5,603,080 A *	2/1997	Kallander et al.	455/14
3,636,912 A	1/1972	Kamp	5,673,053 A	9/1997	Marthinsson	
3,826,935 A	7/1974	Grierson et al.	5,711,014 A *	1/1998	Crowley et al.	
4,167,738 A	9/1979	Kirkendall	5,890,055 A	3/1999	Chu et al.	
4,193,076 A *	3/1980	Ito et al.	6,014,563 A	1/2000	Szabo	
4,220,955 A	9/1980	Frye	6,064,343 A	5/2000	Crowley et al.	
4,481,647 A	11/1984	Gombert et al.	6,108,539 A	8/2000	Ray et al.	
4,661,992 A *	4/1987	Garay et al.	6,112,106 A *	8/2000	Crowley et al.	455/575.7
4,724,766 A	2/1988	LaBudde	6,351,223 B1 *	2/2002	DeWeerd et al.	340/870.03
4,740,794 A *	4/1988	Phillips et al.	6,408,180 B1	6/2002	McKenna et al.	
4,845,738 A	7/1989	Takano	6,594,471 B1	7/2003	Crowley et al.	
4,850,006 A *	7/1989	Sasaki et al.	6,788,935 B1	9/2004	McKenna et al.	
5,016,020 A	5/1991	Simpson	6,885,845 B1 *	4/2005	Crowley et al.	455/9
5,020,149 A	5/1991	Hemmie	7,197,285 B2 *	3/2007	Crowley et al.	455/90.3
5,161,255 A	11/1992	Tsuchiya	2004/0005917 A1 *	1/2004	Crowley et al.	
5,170,173 A	12/1992	Krenz et al.	2007/0173302 A1 *	7/2007	Crowley et al.	
5,193,219 A	3/1993	Tamura	2007/0287473 A1 *	12/2007	Dupray	455/456.1
5,243,355 A	9/1993	Emmert et al.				
5,278,891 A	1/1994	Bhagat et al.				
5,322,991 A *	6/1994	Hanson				
5,335,366 A *	8/1994	Daniels				
5,357,262 A *	10/1994	Blaese				
5,367,556 A	11/1994	Marui et al.				
5,438,610 A	8/1995	Bhagat et al.				
5,444,762 A	8/1995	Frey et al.				
5,450,471 A	9/1995	Hanawa et al.				
5,486,847 A *	1/1996	Ranf et al.				
5,493,702 A *	2/1996	Crowley et al.				
5,517,676 A *	5/1996	Sekine et al.				
5,519,761 A	5/1996	Gilhousen				
5,557,656 A	9/1996	Ray et al.				
5,559,865 A	9/1996	Gilhousen				

FOREIGN PATENT DOCUMENTS

WO WO 1994/28684 A1 12/1994

OTHER PUBLICATIONS

D'Aria, G., et al., "Transmission Techniques for Terrestrial Flight Telephone Systems," *Vehicular Technology Conference*, 1990 IEEE 40th, (1990)[Abstract].

Rograd, R., et al., "Prodat Aeronautical Communication System: Overall Architecture and Preliminary Test Results," *IEEE International Conference on Communications: Communications - Sound to Light*, 1: 0513-0519 (1987).

Uhlirz, M., "Concepts of a GSM-based Communication System for High-speed Trains," *Vehicular Technology Conference, IEEE 44th* Stockholm, Sweden, Jun. 8-10, 1994, pp. 1130-1134 (1994).

* cited by examiner

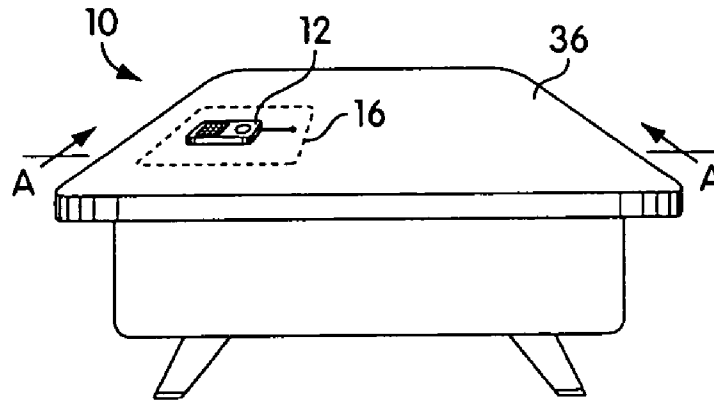

Fig. 1A

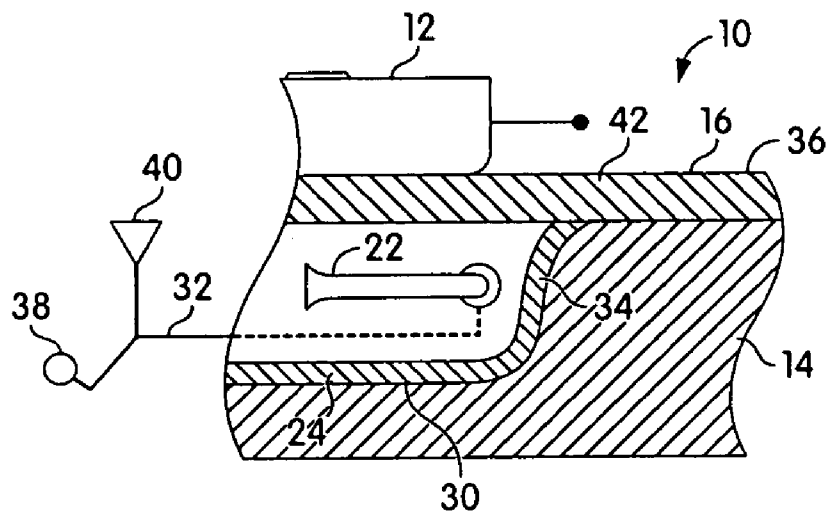

Fig. 1B

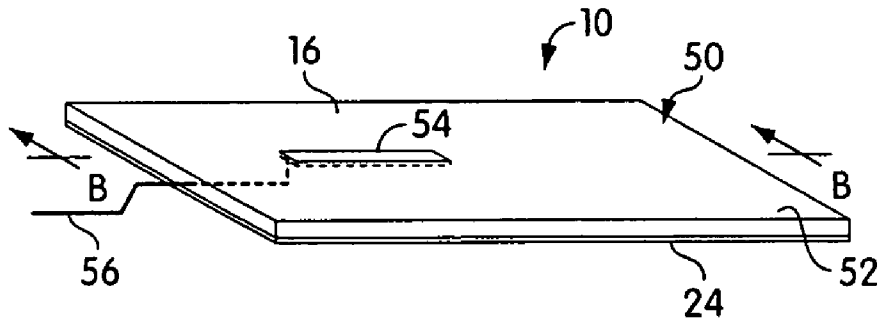

Fig. 2A

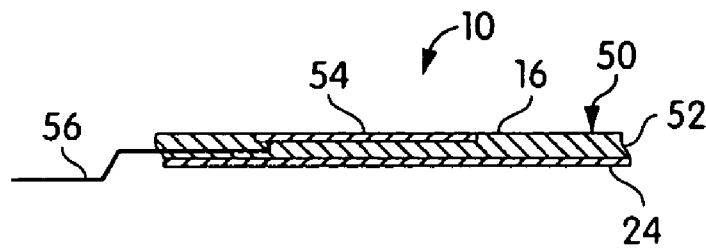

Fig. 2B

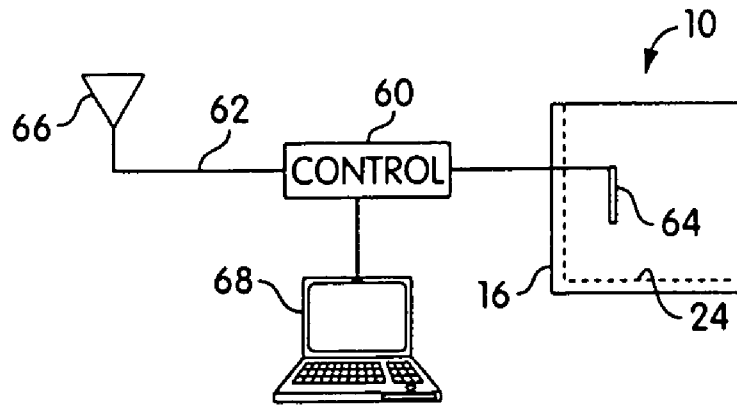

Fig. 3A

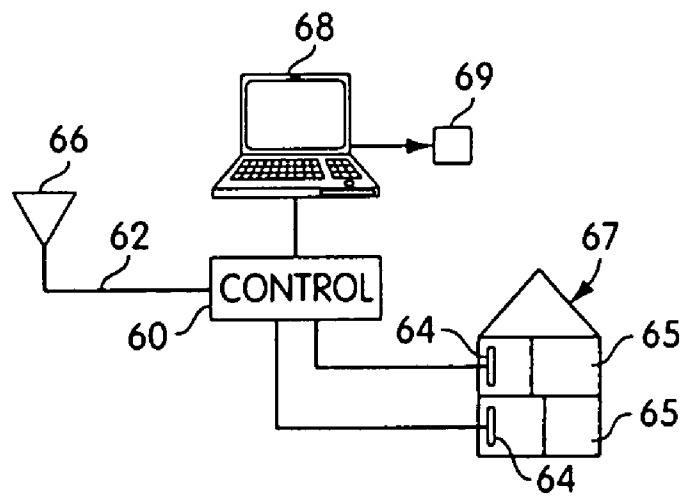

Fig. 3B

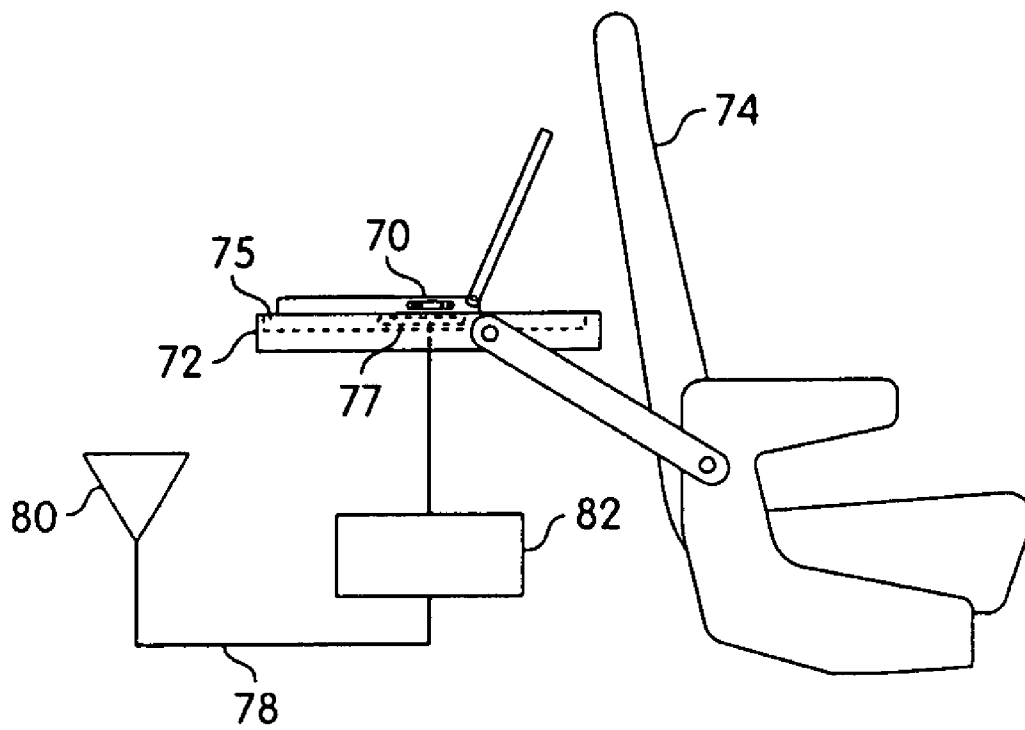

Fig. 4

US 7,400,858 B2

1

**RADIATIVE FOCAL AREA ANTENNA
TRANSMISSION COUPLING
ARRANGEMENT**

PRIOR ART

This invention relates to a coupling system for portable personal electronic communication devices, for use in structures or vehicles, and is a divisional application of Ser. No. 09/634,140, filed Aug. 8, 2000, now U.S. Pat. 6,885,845, which is continuation of 08/604,105 filed Feb. 20, 1996, now U.S. Pat. 6,594,471, which is a CIP of Ser. No. 08/581,065, filed Dec. 29, 1995, now U.S. Pat. No. 5,711,014 and is a CIP of Ser. No. 08/042,879 filed Apr. 5, 1993, now U.S. Pat. No. 5,493,702 each of which is incorporated herein by reference in their entirety.

BACKGROUND OF THE INVENTION

Field of the Invention

Extraneous radio frequency emission has become a serious concern of hand-held electronic communication devices such as portable facsimile machines, ground position indicators, and cellular telephone manufacturers and users alike. RF radiation is considered a potential carcinogen.

The proliferation of these hand-held devices is evident everywhere. A single hand-held device however, should be able to travel with its owner and be easily transferably usable in automobiles, planes, cabs or buildings (including hospitals) as well as at offices and at desks with no restrictions on their use, and without causing concern with regard to the radiation therefrom. The hand-held devices should be portable for a user to carry in his pocket, yet be able to use that same cellular unit in such vehicle or building while minimizing such radiational effect therein.

It is an object of the present invention to permit a user of a portable hand-held electronic communication device such as a cellular telephone or the like, to conveniently use that same hand-held device/cellular phone in an automobile, plane or building, office/desk, or anywhere signal transmission is needed, and to permit such signal to reach its intended destination such as a communications network or satellite, without interfering with other electrical equipment and in spite of interfering walls of buildings or structure and/or other electrical equipment.

It is a further object of the present invention to minimize any radiation from such a portable device, such as a cellular telephone or the like, while such use occurs in an automobile, a building or an elevator, an airplane, a cab, or other public facility in which the user wishes to minimize his own exposure to stray radiation, and also to permit re-transmission of his signal, to avoid the necessity of connecting and disconnecting cables, and to permit a wide variety of cellular telephones such as would be utilized in a rental car where various manufactures' phones would be used, and to permit control of such re-transmission of signals where desired, so as to allow user/customer billing and monitoring thereof.

BRIEF SUMMARY OF THE INVENTION

The present invention comprises a docking system adaptable to an automobile, plane, building or desk for receipt of an electronic communication device such as a cellular telephone, portable computer, facsimile machine, pager or the like, to permit a user safe, environmentally safe, non-touching, radiationally communicative mating of the antenna of

2

that device to a further transmission line through a juxtaposed pick-up probe, the signal coming in or going out through a communications network or further remote antenna.

The docking system may comprise a "zone" or "focal area" as a generally rectilinear area/volume on/in a desk or work surface on/in which the electronic communication device may be placed, such a surface or space being possible on a desk, or in a plane. That focal area may also, in a further embodiment, be comprised of one or more rooms in a building, such focal area having a pick-up probe thereat, in conjunction with a shield placed on/in the desk, room, vehicle or building to prevent the radiation from that communication device from traveling in any undesired directions within the desk, room, vehicle or building.

The focal area may be defined by a metal walled structure within or on which a broadband probe is arranged. The metal walled structure acts as a shield to minimize radiation from the communication device from passing therethrough. In a first embodiment, the shield may be comprised of a partial housing disposed within the upper work surface of a desk. The probe would be elongatively disposed within the partial housing and be in electrical communication with a transmission line such as coax cable, waveguide, or the like. The partial housing may have a planar dielectric layer thereover, which would also be co-planar with the surface of the desk. The communication device would be placed within the pickup zone of the focal area, and would be able to transmit and receive signals through the dielectric layer. The partial housing would act as the shield in the desk, to minimize radiation by the worker at the desk. In a further embodiment, the housing may be comprised of a thin, generally planar mat of conductive material, which mat may be flexible and distortable, for conformance to a particular work surface and for ease of storage capabilities. The mat has an upper layer of dielectric material (for example, plastic, foam or the like). A thin, flat, conformable coupling probe may be embedded into or printed onto the upper surface of the dielectric material. The mat may be utilized as a portable focal area for placement of a communication device thereon, or wrapped up in an enveloping manner therein.

A yet further embodiment of the present invention includes a control unit in the transmission line from the pickup probe to the further remote antenna. The control unit may comprise a filter or switch connected to a computer. The computer may accumulate billing information, control system functions, or act as a regulator for multiple users of the antenna coupling system.

The invention thus comprises a docking system for connecting a portable communication device to a further signal transmission line, the portable communication device having an externally radiative antenna, the system comprising a shield for restricting at least a portion of any radiation from the externally radiative antenna of said portable communication device, and a coupling probe mounted adjacent to the shield for radiatively coupling between the externally radiative antenna of the portable communication device and the further signal transmission line via radio frequency energy therebetween. The shield may be comprised of an electrically conductive material, or an attenuative material capable of blocking at least part of the radiofrequency radiation energy coming from the communication device(s) connected thereto. The shield defines a focal area for receipt and transmission of a radio frequency signal, when a communication device is placed within the focal area. The focal area or zone, may be selected from the group of structures consisting of a desk, a room in a building, or a tray or the like in a vehicle. The further signal transmission line may be connected to a further

US 7,400,858 B2

3

communication network and/or a further antenna connected to the transmission line, yet positioned at a location remote from the shield. The transmission line may have a control unit therein, the control unit being arranged to permit regulation of signals being transmitted through the transmission line. The control unit may comprise a computer arranged to monitor time or use of the docking system. The shield and the probe may be spaced apart by a dielectric material. The shield, the probe and the dielectric material may be flexible. The communication device may include at least two cellular telephones (or other portable communication devices) simultaneously connected to the remote antenna.

The invention also includes a method of coupling a portable communication device having an externally radiative antenna, to a signal transmission line having a further remote antenna thereon, for the purpose of effecting radio signal transmission therebetween, the method comprising the steps of arranging a radiation shield in juxtaposition with at least a portion of said radiative antenna of the portable communication device, mounting a coupling probe adjacent the shield and in communication with the signal transmission line, and placing the externally radiative antenna of the portable communication device close to the probe and the shield so as to permit radiative communication between the externally radiative antenna and the signal transmission line via the coupling probe. The method may include arranging the shield in or on a generally planar work surface so as to restrict the propagation of at least a portion of the radiation emanating from the communication device primarily only to the vicinity of the probe. The method may include attaching a control unit to the transmission line to permit regulation of electric signals therethrough, and adding a further communication device in juxtaposition with a further probe, the further probe also being in electronic communication with that control unit, so as to permit multiple simultaneous use of the transmission line and communication system and/or remote antenna therewith. The method of coupling the portable communication device to the signal transmission line, may also include the step of billing any users of the communication and/or remote antenna by monitoring and tabulating any signals received by and sent through the control unit.

It is an object of the present invention to provide a shielded antenna docking arrangement, which itself may be portable, for use with a portable communication device such as a cellular telephone, facsimile machine or ground position indicator or the like, such use occurring in a vehicle such as a plane, an automobile or a cab or in a public or private building, office desk or elevator.

BRIEF DESCRIPTION OF THE DRAWINGS

The objects and advantages of the present invention will become more apparent when viewed in conjunction with the following drawings in which:

FIG. 1a is a perspective view of a focal area docking arrangement, as may be utilized with a desk;

FIG. 1b is a partial view taken along the lines A-A of FIG. 1a;

FIG. 2a is a perspective view of a portable focal area docking system for portable communication devices;

FIG. 2b is a view taken along the lines B-B of FIG. 2a;

FIG. 3a is a block diagram of a docking system having a sensor unit arranged therewith;

FIG. 3b is a block diagram of a further embodiment of that shown in FIG. 3a; and

FIG. 4 is a side elevational view of a docking system, as it may be utilized in a vehicle.

4

DESCRIPTION OF THE PREFERRED EMBODIMENTS

Referring now to the drawings in detail, and particularly to FIG. 1a, there is shown a portable communication device docking arrangement 10, to permit a portable communication device such as a hand-held cellular telephone 12 to be utilized thereon, such as on a desk 14 or adjacent to it, and as a personal communicator (i.e. cellular telephone, facsimile machine, pager or the like) which may also be carried on an individual.

Such a docking system 10 of the present invention may also be adaptable to an automobile, plane, or building for providing radiationally restrictive communication between a portable electronic communication device 12 such as a cellular telephone, portable computer, facsimile machine, pager, or the like, while allowing communicative mating of the radiative antenna of that device to a further transmission line and communication system and/or a more remote antenna, as recited and shown in our aforementioned patent applications, incorporated herein by reference in their entirety.

The docking system 10 may comprise a "zone" or "focal area" 16 as a rectilinear area/volume on/in a desk 14 or work surface on/in which the electronic communication device 12 may be placed, such a surface or space being in a structure such as an airplane. That focal area 16 has a pick-up coupling probe 22 thereat, as shown for example in FIG. 1b, in conjunction with a shield 24 placed on/in the desk 14, (or room, vehicle or building, as shown in FIGS. 3a and 3b), to prevent the radiation (electromagnetic/microwave) emanating from that communication device 12 from traveling in any undesired directions within the desk, room, vehicle or building.

The focal area 16 may be defined by a metal walled housing structure 30 within which a broadband probe 22 is arranged, as shown in FIG. 1b. The metal walled structure 30 acts as a shield to minimize undesired radiation from the communication device 12 from passing therethrough. In a first embodiment, the shield may be comprised of a partial housing 34 disposed within the upper work surface 36 of a desk 14, as may be seen in FIG. 1b. The pick-up probe 22 would be elongatively disposed within the partial housing structure 30 and be in electrical communication with a transmission line 32 such as coaxial cable, waveguide, or the like. The transmission line 32 would be in electrical communication with an electric communications network or distribution system 38, and/or to a further remote antenna 40, such as may be seen in FIGS. 1b, 3a and 3b. The partial housing 30 may have a planar dielectric layer 42 thereover, which would also be co-planar with the surface of the desk 14. The communication device 12 would be placed within the pickup zone of the focal area 16, and would be able to transmit and receive signals through the dielectric layer 42. The partial housing 30 would act as the shield in the desk, to minimize radiation directed towards the worker(s) at the desk.

In a further embodiment as shown in FIG. 2a, the shield or housing may be comprised of a thin, generally planar mat 50 of conductive material, which mat 50 may be flexible and distortable, for conformance to any surface (human or otherwise), and may be folded or rolled up to minimize storage requirements. The mat 50 has an upper layer 52 made of a dielectric material (plastic, foam or the like). A thin, flat, conformable coupling probe 54 is embedded into or printed onto the upper surface of the layer of dielectric material 52. The mat 50 may be utilized as a portable focal area for placement of a communication device thereon, or wrapped-up in an enveloping manner therein. The probe 54 is con-

US 7,400,858 B2

5

nected to a transmission line 56, in electrical contact with a network or remote antenna, not shown in this figure.

A yet further embodiment of the present invention includes a control unit 60, connected into the transmission line 62 from the pickup probe 64 to the further remote antenna 66 shown in FIGS. 3a and 3b. The control unit 60 may comprise a filter, switch, amplifier, attenuator, combiner, splitter, or other type of frequency converter, connected to a computer 68. The computer 68 may be arranged to accumulate customer or billing information by functioning with a processor to print out use-data 69, to maintain frequency control functions, or to act as a regulator for multiple users of the antenna coupling system 10. There may be a plurality of pickup coupling probes 64 each connected to the control unit 60 and the transmission line 62, one probe 64 in each of a plurality of shielded rooms 65, each wall or work area(desk) having a shield, the rooms 65 shown in a building 67, in FIG. 3b.

The view shown in FIG. 4, displays a portable communication device such as a facsimile machine or computer 70 supported on a tray 72 articulably mounted on the back of an airplane seat 74. The tray 72 has a "focal area" 75 therewithin, as represented by the dashed lines 76. The focal area 75 includes a conductive (preferably metallic) shield arranged beneath and partially surrounding a broadband probe 77. The probe 77 transmits electrical signals radiated to and from a radiative antenna on or in the base of the portable communication device 70. A transmission line 78 which may be comprised of coaxial cable, waveguide, or optical fibers, extends from the probe within the focal area, to a further remote antenna 80 mounted outside of the structure, which here, is identified as an airplane.

A control unit 82, such as attenuators, heterodyne converters, amplifiers, bandpass filters, switches, or the like, may be arranged in communication with the transmission line 78 to monitor or control the time in the vehicle in which the communication device may be utilized, for example, to limit certain times when such devices may be utilized in an airplane, or to modulate the signal being transmitted or received by the remote antenna, and/or to monitor usage of the docking system for subsequent billing of those users.

Thus what has been shown is a unique system for minimizing the detrimental effects of radiation from common portable communication devices to their users, while improving the transmission capabilities and customer usage of such devices, overcoming the barriers such as buildings and vehicles in which such devices might otherwise be utilized, that would interfere with the flow of signals transmitted.

We claim:

1. A system for enabling communication from personal computer communication devices located within a passenger vehicle to a distant communication system located outside of said passenger vehicle, each of said personal computer devices having a radiative RF antenna, said system comprising:

at least one first RF antenna arranged within said passenger vehicle to communicate an RF signal wirelessly with said personal computer communication devices;

at least one second RF antenna arranged to radiate outside of said passenger vehicle to wirelessly communicate with said distant communication system located outside of said passenger vehicle;

a control computer arranged to control a communications link between said at least one of said first RF antenna within said passenger vehicle and said at least one second RF antenna arranged to radiate outside of said passenger vehicle, said control computer arranged to control use and time in which said personal computer

6

communication devices are enabled to communicate with said distant communication system outside of said passenger vehicle, wherein said passenger vehicle is an aircraft.

2. The system as recited in claim 1, wherein said control computer operates to filter or switch communication of said personal computer communication devices within said passenger vehicle and said distant communication system outside of said passenger vehicle.

3. The system as recited in claim 1 wherein said control computer operates to control the time said personal computer communication devices are enabled to wirelessly communicate by RF communication through said system, and to bill for the time said personal computer communication devices are communicatively enabled within said passenger vehicle.

4. The system as recited in claim 1, wherein said control computer enables the monitoring of wireless RF communication between said personal computer communication devices within said passenger vehicle and said distant communication system.

5. The system as recited in claim 1, wherein said distant communication system comprises a satellite.

6. The system as recited in claim 1, wherein said passenger vehicle has an RF signal shield arranged therein to restrict undesired travel of a wireless RF signal transmission within said passenger vehicle.

7. A method of utilizing a variety of different radiatively communicative wireless personal RF communication devices within a local environment in an aircraft, in RF communication with a communication system distant from said local environment, comprising:

arranging at least one first RF antenna within said local environment;

arranging at least one second RF antenna radiating outside of said passenger vehicle defining said local environment;

operating a control computer in a communications link between said at least one said first RF antenna within said local environment and said at least one second RF antenna arranged to radiate outside of said local environment;

wirelessly communicating RF signals between a radiative RF antenna of said variety of personal communication devices and said at least one first RF antenna;

controlling said RF signals sent between said variety of different radiatively communicative wireless personal RF communication devices within said local environment and said second RF antenna radiating outside of said local environment, by said control computer; and

limiting the time said variety of different radiatively communicative wireless personal RF communication devices may be utilized to communicate wirelessly by an RF signal, from within said local environment of said aircraft to said at least one second RF antenna radiating outside of said local environment.

8. The method as recited in claim 7, including:

filtering said RF signals sent between said radiatively communicative wireless personal RF communication devices within said local environment and said second RF antenna radiating outside of said local environment, by said control computer.

9. The method as recited in claim 7, including:

regulating use of multiple wireless personal RF communication devices located within said local environment, by said control computer.

US 7,400,858 B2

7

10. The method as recited in claim 7, including:
shielding at least a portion of said local environment to
restrict undesired travel of wireless RF signals within
said local environment.

11. The method as recited in claim 7, wherein said at least 5
one of said variety of different radiatively communicative
wireless RF communication devices utilized within said local
environment, comprises a laptop computer.

12. The method as recited in claim 7, wherein said local 10
environment comprises at least a partially RF signal shielded
area.

13. A method of utilizing a variety of different radiatively
communicative wireless personal RF communication devices
within a local RF restricted environment, which environment 15
is selected from the group consisting of: an automobile, a
building, an elevator, an airplane or a desk, so as to enable RF
signal communication between said different radiatively
communicative wireless personal RF communication devices
with a communication system distant from said local envi-
ronment, the method comprising: 20

arranging at least one first RF antenna within said local RF
restricted environment;

arranging at least one second RF antenna radiating outside
of said local RF restricted environment;

placing a control computer in a communications link 25
between said at least one said first RF antenna within
said local RF restricted environment and said at least one
second RF antenna radiating outside of said local RF
restricted environment;

8

wirelessly communicating wireless RF signals between an
RF radiative antenna of said personal communication
devices and said at least one first RF antenna, in a
spaced-apart and non-touching manner;

controlling said RF signals and limiting the time said RF
signals are sent between said variety of different radi-
atively communicative wireless personal RF communi-
cation devices within said RF restricted environment
and said second RF antenna radiating outside of said RF
restricted environment, by said control computer.

14. The method as recited in claim 13, including:
RF shielding at least a portion of said local RF restricted
environment to control undesired travel of any of said
wireless RF signals communicated within said local RF
restricted environment.

15. The method as recited in claim 13, including:
billing for use of any of said variety of different radiatively
communicative RF communication devices utilized
within said RF restricted environment.

16. The method as recited in claim 13, including:
arranging a plurality of first RF antennae within said local
RF restricted environment.

17. The method as recited in claim 13, wherein at least one
of said radiatively communicative wireless personal RF com-
munication devices is a personal laptop computer.

* * * * *