



# Onboard Network System

Inmarsat Conference  
June 3 – 5, 2009

**John Craig**  
Cabin & Network Systems

# Agenda

- **e-Enabling at Boeing**
- **Onboard Network System**
- **SATCOM Offerings at Boeing**
- **The Future of Connectivity**

# The Future of Aircraft Networks

As the consumer market becomes a more dominant force in influencing aircraft avionics, the industry is at a crossroads facing a significant paradigm shift. Next generation airplanes will employ Ethernet based networks. These networks will connect aircraft systems together in ways that will leverage each other much more than in previous designs. With these integrated architectures we must tackle issues such as security while taking advantage of ground connectivity and a connected fleet. This will open new frontiers in maintenance, entertainment, and system flexibility.

# e- Enabling at Boeing

# The Classic Avionics Paradigm

- **Proprietary systems**

- Unique development
- High cost for upgrades – obsolescence/new features

- **Unique stand alone solutions**

- Suppliers develop unique solutions

- **Functional stovepipes**

- Integration done at interface vs. functional level.

# Connectivity Encompasses Several Traditionally Separated Functionalities

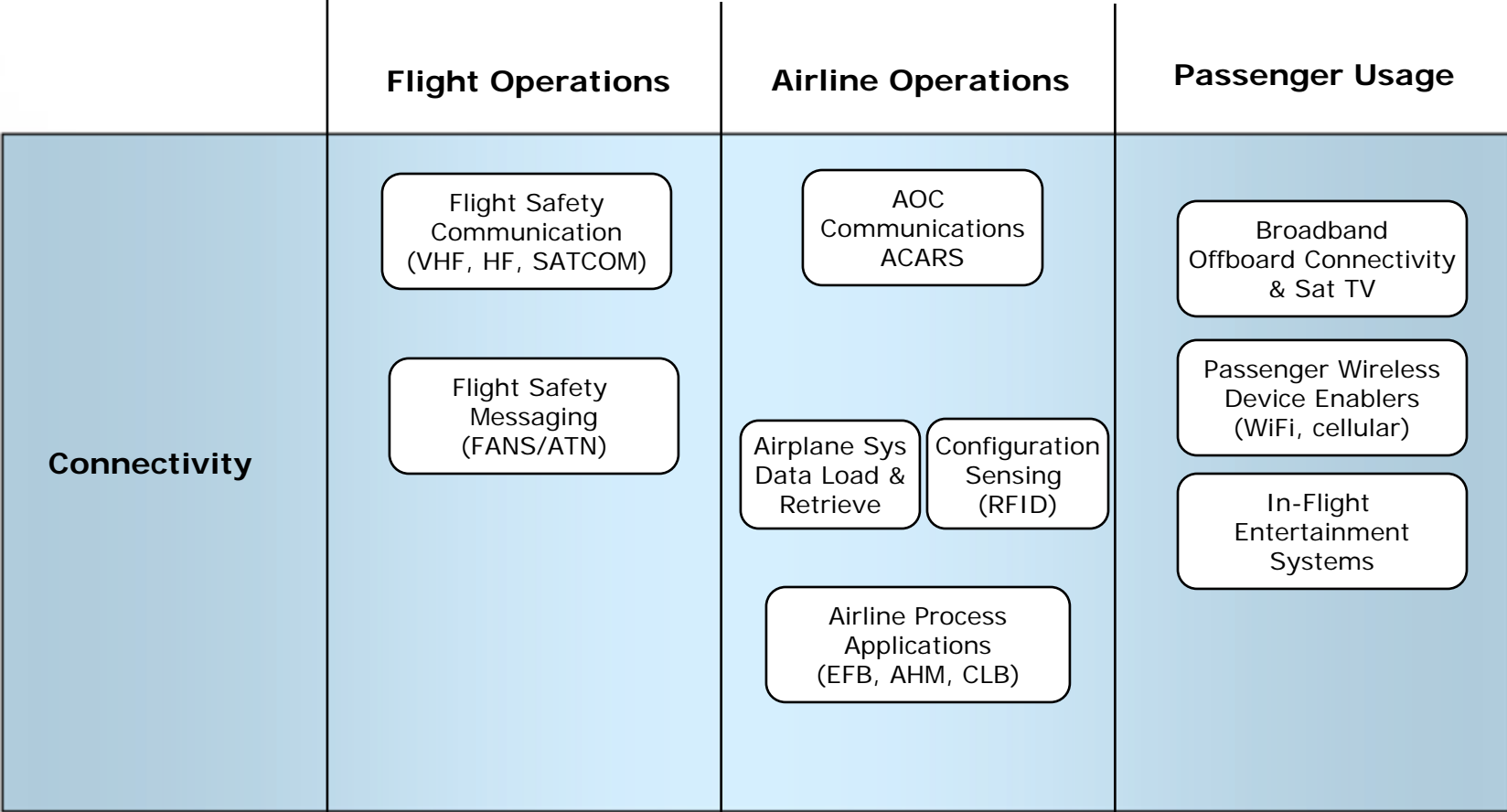

# Scope of the Onboard Network System (Conceptual)

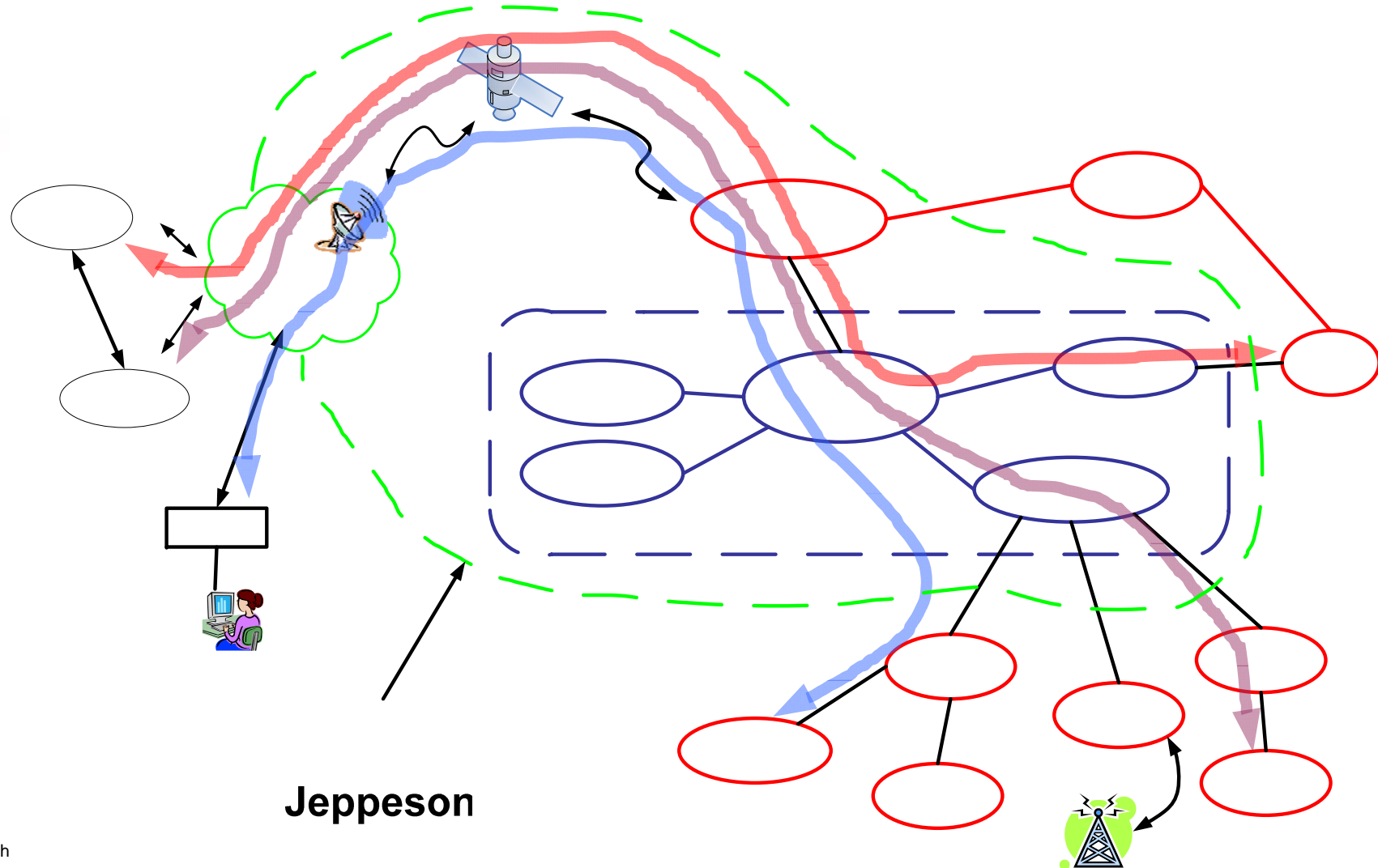

**Jeppeson**

# The Network Paradigm

- **New issues impacting installed systems**
  - H/W obsolescence .
  - S/W upgrades/security patches.
  - H/W – S/W compatibility
- **Business Issues with upgrades at Airline**
  - Will need to plan for issues similar to office computing
  - Costs will have to be factored when implementing
- **Will need to model office “IT” model**
  - Active management of networks
  - Similar to the evolution of the office computing environment

# Network Security

- **Transition to IP public networks**
  - Protection against malicious activity
  - Security against unauthorized access
- **Perceptions...**
  - Connectivity options typically non-essential
  - Misconceptions by the public



# Onboard Network System

# The ONS Vision

- **Transition to a common hardware platform**
  - Common, open, scalable solutions
  - Leverage other networks on the airplane
- **Transition to a single operating system**
  - Layered software with common interfaces to applications
  - Ability to run on multiple platforms
  - Open interfaces leveraging commercial standards
- **Functionality transition from a hardware based to software driven solutions**
- **Open interfaces (Hardware/Software)**

# Functional Solutions

- **Systems are transitioning from a hardware based solution to a functional (software driven) solution.**
- **The operating systems will need to support transfer of applications between multiple hardware platforms**

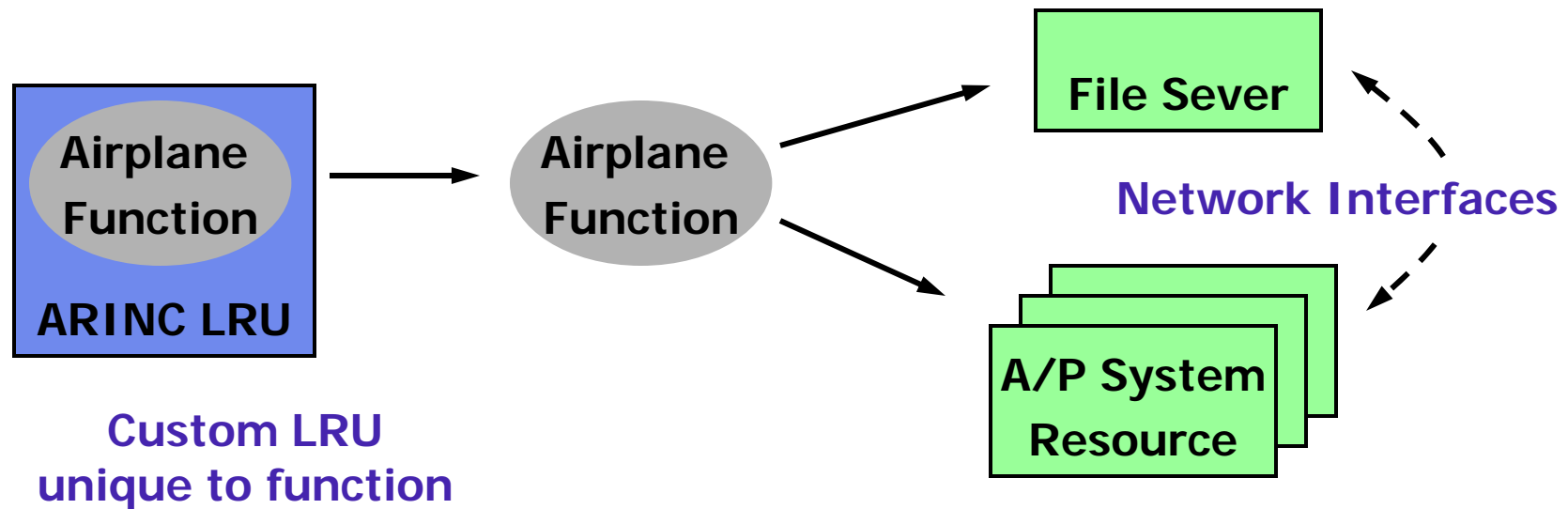

# Key Elements

## Airborne Elements

- Onboard Network System
  - Interfacing Systems
- Operational Applications
- Passenger Interfaces

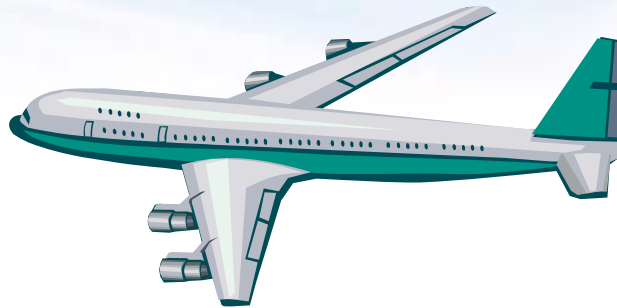

## Air and Ground Link

- TWLU
- Satcom (L-Band)
  - Ku Satellite
  - Sat TV



## End User Client

- Airline
- www
- Boeing
- End App Supplier

## Service Providers (i.e.)

- On-Air
- AeroMobile
- Inmarsat
- Panasonic
- Thales
- ARINC/SITA



# 747-8 Onboard Network System (ONS)

- **Network File Server based system**
  - Uses upgraded part delivered with EFB/NFS configurations
  - Adds Network Extension Device (A763 package) for switch/router functions and additional 429/discrete capability.
  - 2MCU form factor – scalable by adding additional file servers or devices.
  - Introduced into ARINC to establish standard.



Network Extension Device (NED)



Network File Server (NFS)

# 747-8F ONS Functionality

## Applications

- Data loading – ARINC 615A / 615-4
- Intelligent Engines ACARS Proxy
- Hosting Engine Trim Balance GUI
- Wireless Staging of LSAPs on the ONS
- Weight & Balance Application
- Hosting the optional logbook application
- Hosting of new Boeing applications as they are developed via the CNAS framework
- IP Communications Manager for TWLU/SATCOM

# SATCOM Offerings at Boeing

# 777 Airplane Offerings

- **777 Passenger – ARINC 741 and ARINC 781 Systems**

- Avionics (alphabetical order)

- Honeywell MCS7200 – ARINC 741, TSA signed
    - Rockwell/Collins SAT2200 – ARINC 781, TSA requested, in work
    - Thales TopFlight – ARINC 781, TSA signed

- Antenna systems (alphabetical order)

- Chelton HGA7001 – ARINC 781, deliveries since Nov 2007
    - CMC Electronics CMA-2102SB – ARINC 741, TSA signed
    - Evaluating EMS Technologies AMT-3800 ARINC 781 antenna system – TSA Requested

- **777 Freighter – ARINC 781 Systems Only**

- Avionics (alphabetical order)

- Rockwell/Collins SAT2200 – ARINC 781, TSA requested, in work
    - Thales TopFlight – ARINC 781, TSA signed

- Antenna systems (alphabetical order)

- Chelton HGA7001 – ARINC 781, deliveries since Nov 2007
    - Evaluating EMS Technologies AMT-3800 ARINC 781 antenna system – TSA Requested

# 737/747-8/767 Airplane Offerings

- **737 – ARINC 781 Systems Only**
  - Avionics
    - Thales TopFlight – TSA signed
    - Rockwell/Collins SAT2200 – TSA requested, in work
  - Antenna systems
    - Chelton HGA7001 – TSA nearly complete
    - Evaluating viability of IGA for multi-service
  
- **747-8 – ARINC 781 Rockwell/Collins System Basic**
  - SAT-2200 Avionics
  - HGA-2100 High Gain Antenna system
  
- **767 – ARINC 741, 761, and 781 Classic Systems**
  - Avionics
    - Rockwell/Collins SAT-906 (ARINC 741)
    - Rockwell/Collins SAT2100 (ARINC 761)
    - Honeywell MCS7000 (ARINC 741)
  - Antenna Systems
    - CMC Electronics CMA-2102 (ARINC 741)
    - Chelton HGA7001 (ARINC 781)



# The Future of Connectivity

# Airplane Functional Interfaces

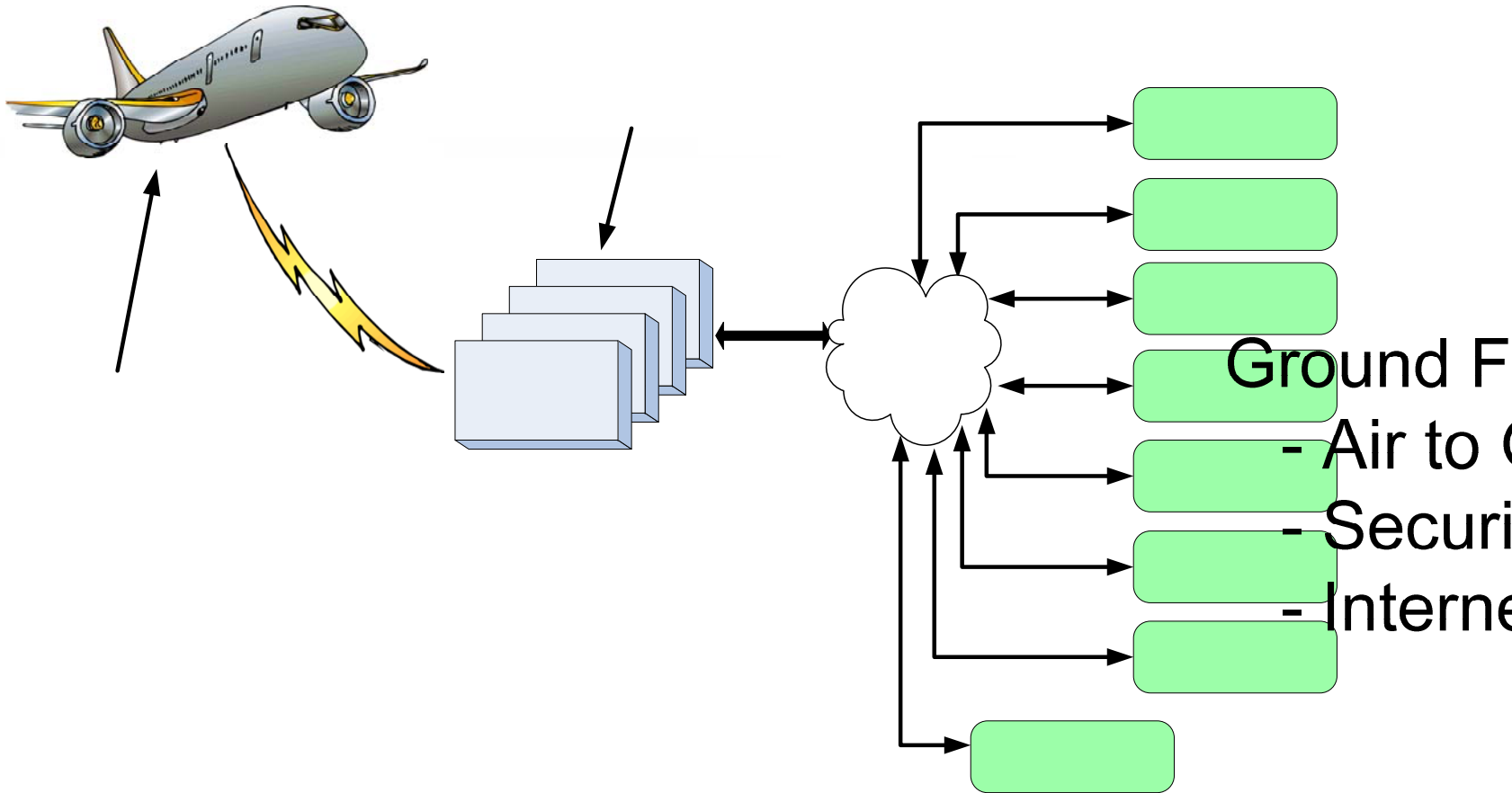

# SATCOM IP Control

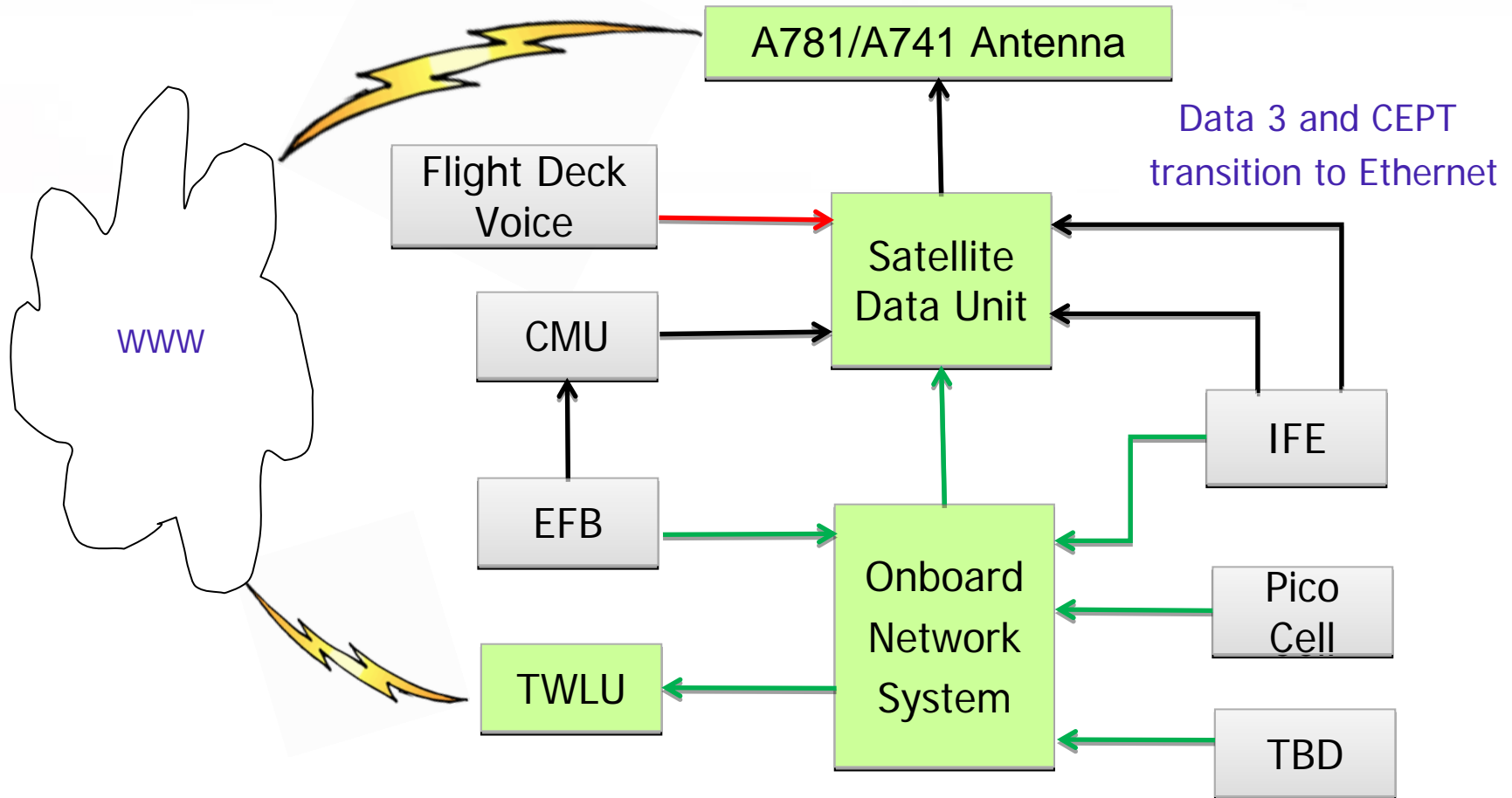

ONS as the IP Gateway  
for Offboard Communication

# Offboard IP Connectivity

- **Connectivity primarily through the Onboard Network**
- **Communication management easily configurable**
- **Service providers and interfacing systems will need to operate with each others equipment**
- **Boeing will not become a service provider**
- **Boeing will work with a Service Providers to ensure system is integrated in an open architecture**



# Vision for an e-Enabled Environment

*The right information to the right people  
at the right time for better decision making*

Technology to integrate  
airline and airplane

Disruption recovery  
and management

- Maintenance optimization
- Health prognosis
- Scheduling/task optimization
- Integrated inventory

- Flight operations
  - Planning
- Decision support
- Information dissemination

Cabin/Crew Services

ATC  
integration



Optimized  
efficiency, safety,  
security and  
passenger  
experience

Several years

Year

Month

Week

Hour

Customer experience

Planning

Investment

Airplane

Maintenance  
and Engineering

Airline  
Operations

Commercial  
Operations

# Steps Forward

- **Open requirements must be developed between:**
  - Airborne systems and offboard links
  - Offboard links and ground systems
- **Network Security must be addressed**
  - Safety of Critical and Essential Systems
  - Airline Operations
  - Public Perception
- **Leverage all the systems available in a networked system**